

CATALOG NUMBER	WIRE RANGE	STUD SIZE [METRIC SIZE]	HYDRAULIC TOOLING				DIELESS TOOLING	NO. OF CRIMPS	WIRE STRIP LENGTH
			DIE INDEX	TOOL CAT. NO.	DIE TYPE	DIE CAT. NO.			
YAD25M16E58	1/0 AWG STR.CU CODE & FLEX [35 - 50] mm <sup>2</sup>	5/8" [16]	1019	Y35, Y39, Y750, PAT750	NEST	UV26L	Y81KFT- SERIES PAT81KFT- SERIES Y4PC834- SERIES PAT4PC834- SERIES	1	3/4"
					INDENTOR	Y34PA			

REV	DATE	DESCRIPTION	ECO	BY	C'H'K.
A	10/30/12	CREATE INDIVIDUAL SALES DRAWINGS AS PER MARK-UP	29245	VK	MA

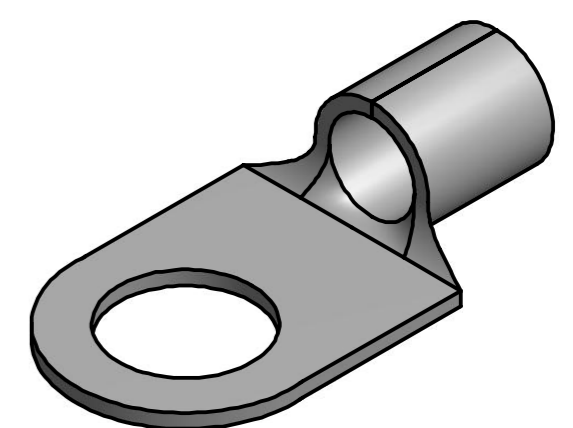
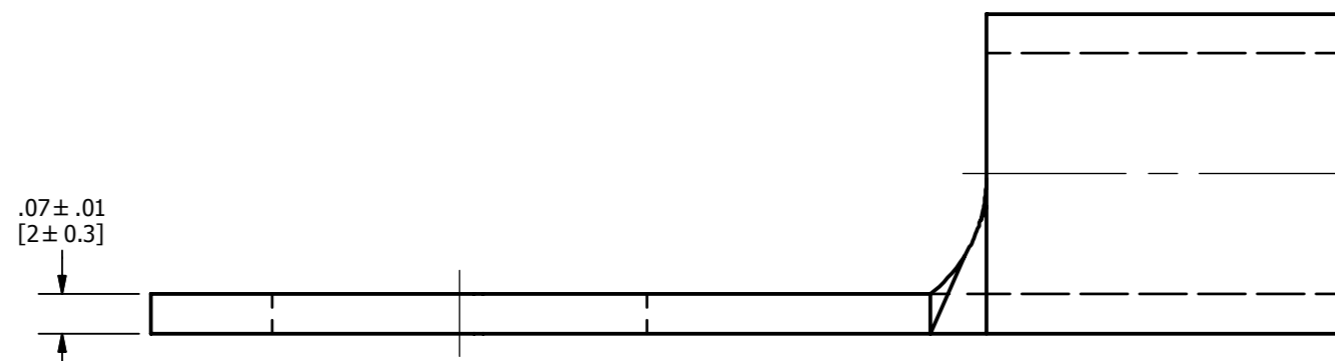
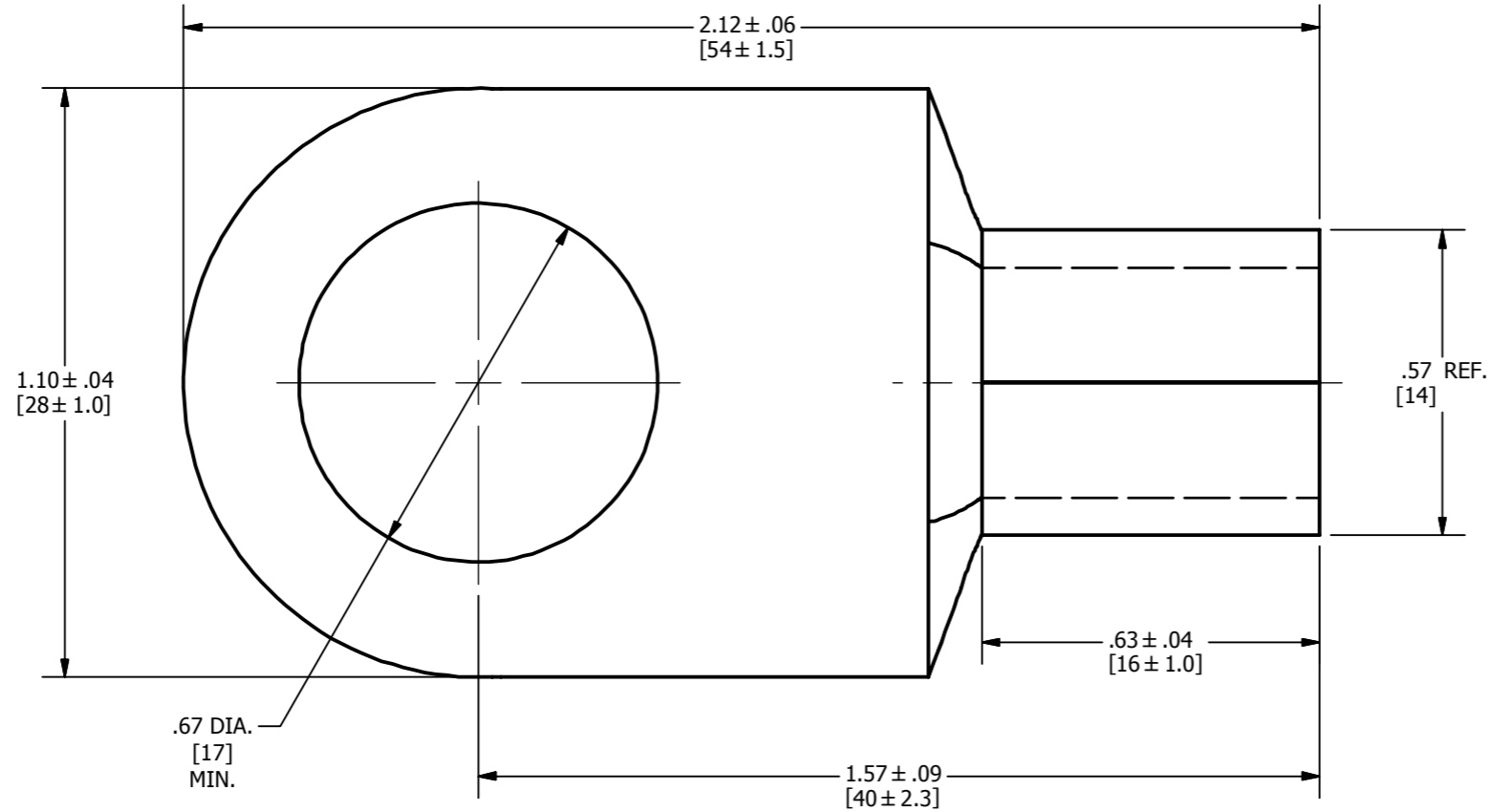

NOTES:

1. MATERIAL: COPPER.
2. FINISH: TIN PLATED.
3. Y35P3 ADAPTOR REQUIRED FOR Y34PA INDENTORS IN Y35, Y39, Y750 AND PAT750 TOOLS.
4. DIMENSIONS IN BRACKETS [ ] ARE IN MILLIMETERS ROUNDED OFF TO THE NEAREST MILLIMETER, UNLESS OTHERWISE NOTED, AND ARE FOR REFERENCE ONLY.

TO ORDER BURNDY PRODUCTS CALL		NON-INSULATED BRAZED BARREL COPPER TERMINAL	
UNITED STATES		ITEM NO: 50002461	
1-800-346-4175 (LONDONDERRY, NH)		CAT. NO: YAD25M16E58	
CANADA:		DRAWN BY: V KAMAL 10/30/12	
1-800-361-6975 (QUEBEC)		CHECKER: J MICHAUD 11/27/12	
1-800-387-6487 (ALL OTHER PROVINCES)		DSN APRVL: J MICHAUD 11/27/12	
FOR PRODUCT INFO: <a href="http://www.burndy.com">http://www.burndy.com</a>		MFG APRVL: --	
		QA APRVL: C KOWALCZYK 11/29/12	
		MKT APRVL: S GALE 11/21/12	
		PROD FAM:	
		PROJECT #:	
		DOCUMENT TYPE: Sales	
		REL LEVEL: Released	
		SIZE	DRAWING NO
		B	50013729
			REV
			A
		SHEET 1 OF 1	

